

Concurrency, Threads, and Events

CS 6410: Advanced Systems

Fall 2024

Hakim Weatherspoon

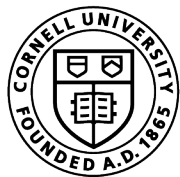

Cornell Bowers CIS
Computer Science

On the Duality of Operating System Structure

- Hugh C. Lauer
 - Adjunct Prof., Worcester Polytechnic Institute
 - Xerox, Apollo Computer, Mitsubishi Electronics Research Lab, etc.
 - Founded a number of businesses:
Real-Time Visualization unit of
Mitsubishi Electric Research Labs (MERL)



- Roger M. Needham
 - Prof., Cambridge University
 - Microsoft Research, Cambridge Lab
 - Kerberos, Needham-Schroeder security protocol, and key exchange systems



Message vs Procedure oriented systems (i.e. Events vs Threads)

- Are they really the same thing?
- Lauer and Needham show
 - 1) two models are duals
 - Mapping exists from one model to other
 - 2) dual programs are logically identical
 - Textually similar
 - 3) dual programs have identical performance
 - Measured in exec time, compute overhead, and queue/wait times

Message-oriented system (Event)

- Small, static # of process
- Explicit messaging
- Limited data sharing in memory
- Identification of address space or context with process

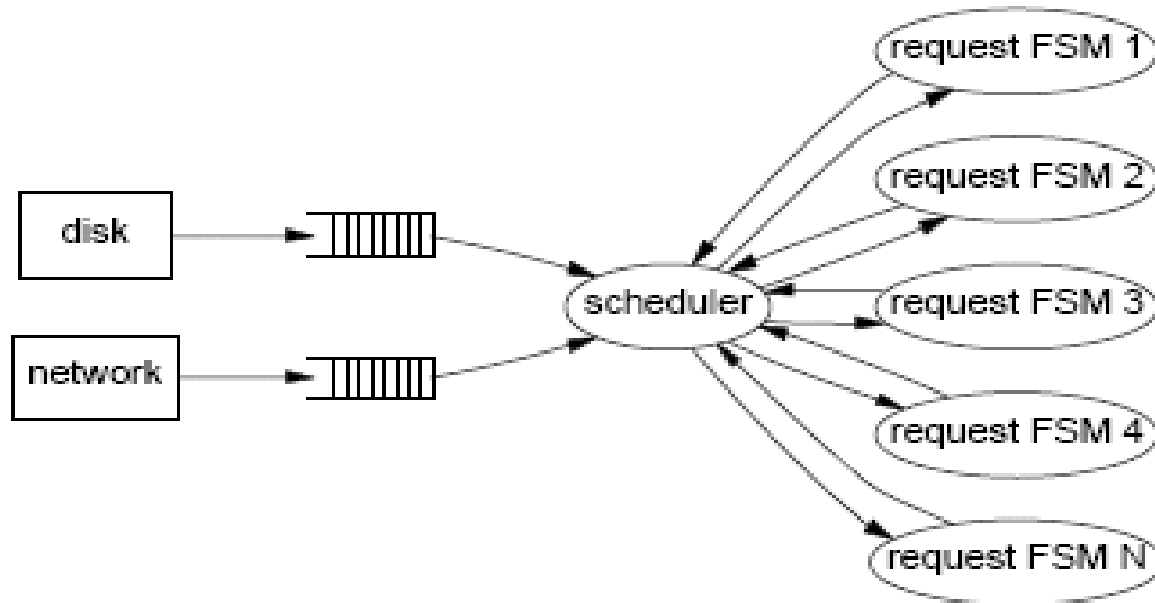

Message-oriented system

- Characteristics
 - Queuing for congested resource
 - Data structure passed by reference
(no concurrent access)
 - Peripheral devices treated as processes
 - Priority of process statically determined
 - No global naming scheme is useful

Message-oriented system

- Calls:
 - SendMessage, AwaitReply
 - SendReply
 - WaitForMessage
- Characteristics
 - Synchronization via message queues
 - No sharing of data structures/address space
 - Number of processes static

Message-oriented system

- Canonical model
 - begin
 - Do forever
 - WaitForMessages
 - case port
 - port 1: ...;
 - port 2: ...; SendReply; ...;
 - end case
 - end loop
 - end

Procedure-Oriented System (Thread)

- Large # of small processes
- Rapidly changing # of processes
- Communication using direct sharing and interlocking of data
- Identification of context of execution with function being executed

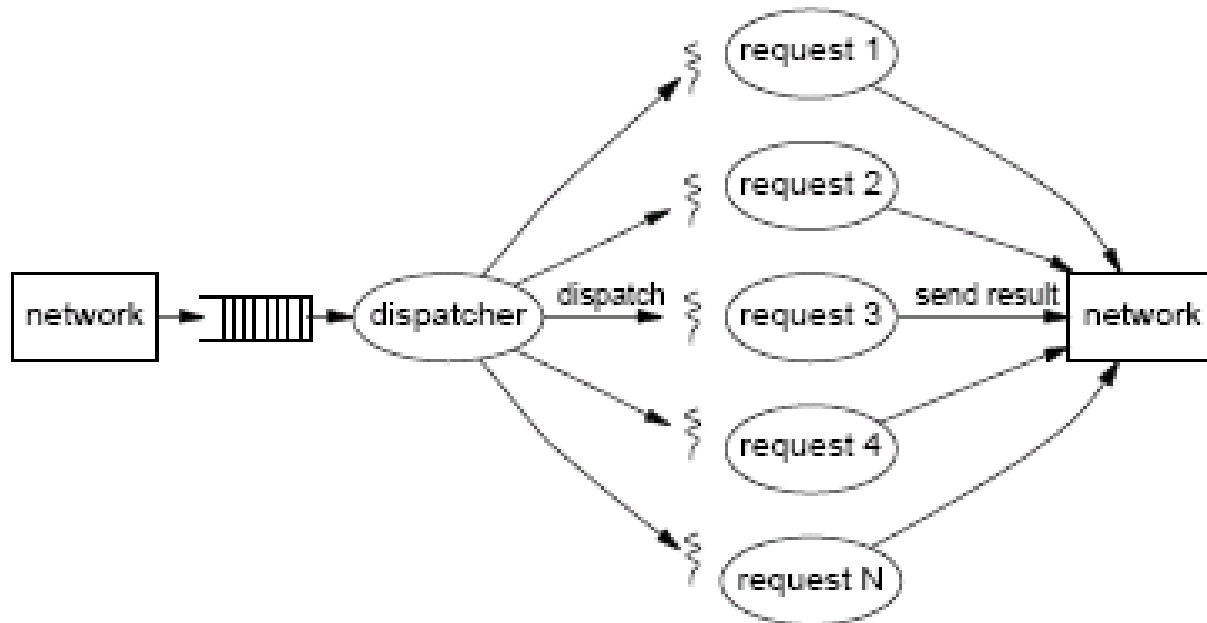

Process-oriented system

- Characteristics
 - Synchronization and congestion control associates with waiting for locks
 - Data is shared directly and lock lasts for short period of time
 - Control of peripheral devices are in form of manipulating locks
 - Priority is dynamically determined by the execution context
 - Global naming and context is important

Process-oriented system

- Calls:
 - Fork, Join (process)
 - Wait, Signal (condition variables)
- Characteristics
 - Synchronization via locks/monitors
 - Share global address space/data structures
 - Process (thread) creation very dynamic and low-overhead

Process-oriented system

- Canonical model

- Monitor

- global data and state info for the process

- proc1: ENTRY procedure

- proc2: ENTRY procedure returns

- begin

- If resourceExhausted then WAIT; ...;

- RETURN result; ...;

- end

- proc L: ENTRY procedure

- begin

- ...; SIGNAL; ...

- end;

- endloop;

- initialize;

- end

Dual Mapping

Event	Thread
Processes: CreateProcess	Monitors: NEW/START
Message channel	External procedure id
Message port	Entry procedure id
Send msg (immediate); AwaitReply	Simple procedure call
Send msg (delayed); AwaitReply	FORK; ... JOIN
Send reply	Return from procedure
Main loop of std resource manager, wait for message stmt, case stmt	Monitor lock, ENTRY attribute
Arms of case statement	ENTRY proc declaration
Selective waiting	Condition vars, WAIT, SIGNAL

Preservation of Performance

- Performance characteristics
 - Same execution time
 - Same computational overhead
 - Same queuing and waiting times
- Do you believe they are the same?
- What is the controversy?

SEDA: An Architecture for Well-Conditioned, Scalable Internet Services (Welsh, 2001)

- 20 to 30 years later, still controversy!
- Analyzes threads vs event-based systems, finds problems with both
- Suggests trade-off: stage-driven architecture
- Evaluated for two applications
 - Easy to program and performs well

SEDA: An Architecture for Well-Conditioned, Scalable Internet Services (Welsh, 2001)

- Matt Welsh
 - Cornell undergraduate Alum (Worked on U-Net)
 - PhD from Berkeley (Worked on Ninja clustering)
 - Prof. at Harvard (Worked on sensor networks)
 - Currently at Google
- David Culler
 - Faculty at UC Berkeley
- Eric Brewer
 - Faculty at UC Berkeley (currently VP at Google)

What is a thread?

- A traditional “process” is an address space and a thread of control.
- Now add multiple thread of controls
 - Share address space
 - Individual program counters, registers, and [funcation call] stacks
- Same as multiple processes sharing an address space.

Thread Switching

- To switch from thread T1 to T2:
 - Thread T1 saves its registers (including pc) on its stack
 - Scheduler remembers T1's stack pointer
 - Scheduler restores T2' stack pointer
 - T2 restores its registers
 - T2 resumes

Thread Scheduler

- Maintains the stack pointer of each thread
- Decides what thread to run next
 - E.g., based on priority or resource usage
- Decides when to pre-empt a running thread
 - E.g., based on a timer
- Needs to deal with multiple cores
 - Didn't use to be the case
- “fork” creates a new thread

Synchronization Primitives

- Semaphores
 - $P(S)$: block if semaphore is “taken”
 - $V(S)$: release semaphore
- Monitors:
 - Only one thread active in a module at a time
 - Threads can block waiting for some condition using the WAIT primitive
 - Threads need to signal using NOTIFY or BROADCAST

Uses of threads

- To exploit CPU parallelism
 - Run two threads at once in the same program
- To exploit I/O parallelism
 - Run I/O while computing, or do multiple I/O
 - I/O may be “remote procedure call”
- For program structuring
 - E.g., timers

Common Problems

- Priority Inversion
 - High priority thread waits for low priority thread
 - Solution: temporarily push priority up (rejected??)
- Deadlock
 - X waits for Y, Y waits for X
- Incorrect Synchronization
 - Forgetting to release a lock
- Failed “fork”
- Tuning
 - E.g. timer values in different environment

What is an Event?

- An object queued for some module
- Operations:
 - `create_event_queue(handler) → EQ`
 - `enqueue_event(EQ, event-object)`
 - Invokes, eventually, `handler(event-object)`
- Handler is *not* allowed to block
 - Blocking could cause entire system to block
 - But page faults, garbage collection, ...

Example Event System

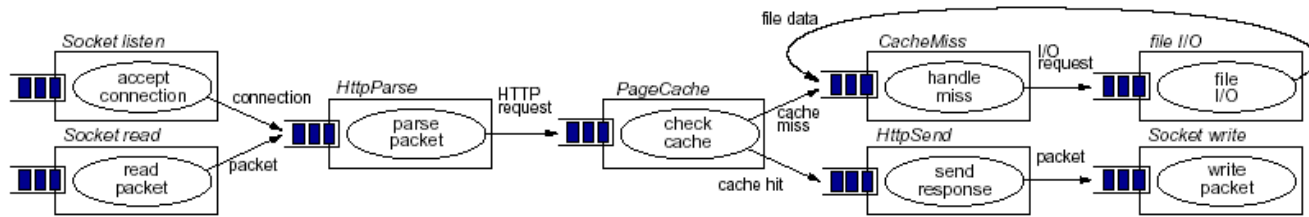

(Also common in telecommunications industry, where it's called "workflow programming")

Event Scheduler

- Decides which event queue to handle next.
 - Based on priority, CPU usage, etc.
- Never pre-empts event handlers!
 - No need for stack / event handler
- May need to deal with multiple CPUs

Synchronization?

- Handlers cannot block → no synchronization
- Handlers should not share memory
 - At least not in parallel
- All communication through events

Uses of Events

- CPU parallelism
 - Different handlers on different CPUs
- I/O concurrency
 - Completion of I/O signaled by event
 - Other activities can happen in parallel
- Program structuring
 - Not so great...
 - But can use multiple programming languages!

Common Problems

- Priority inversion, deadlock, etc. much the same with events
- Stack ripping

Threaded Server Throughput

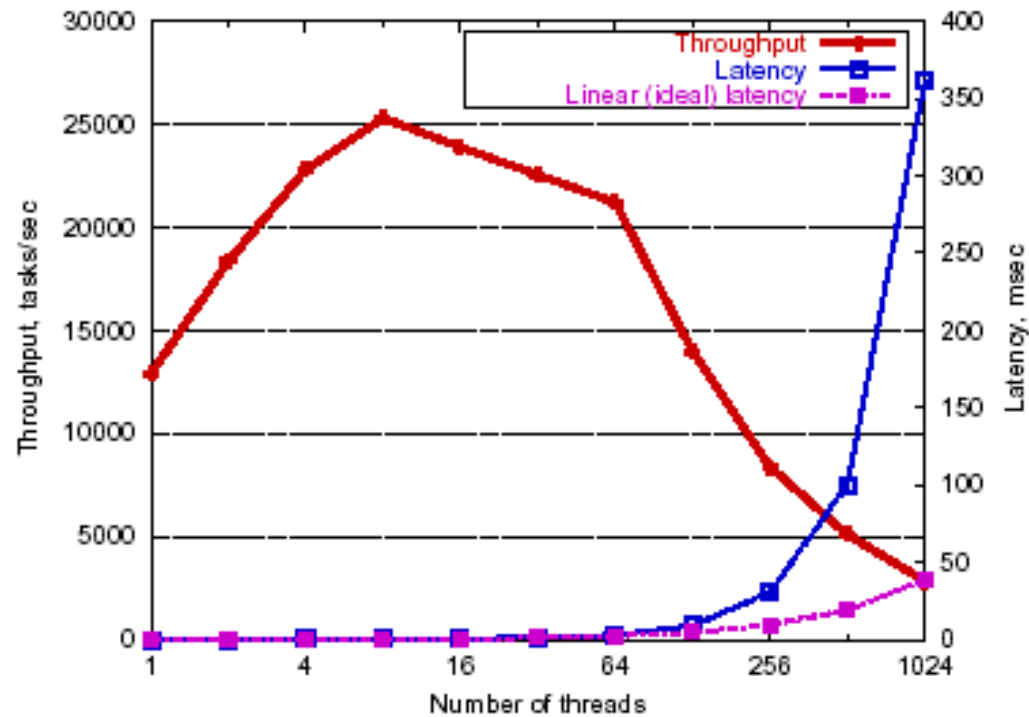

Event-driven Server Throughput

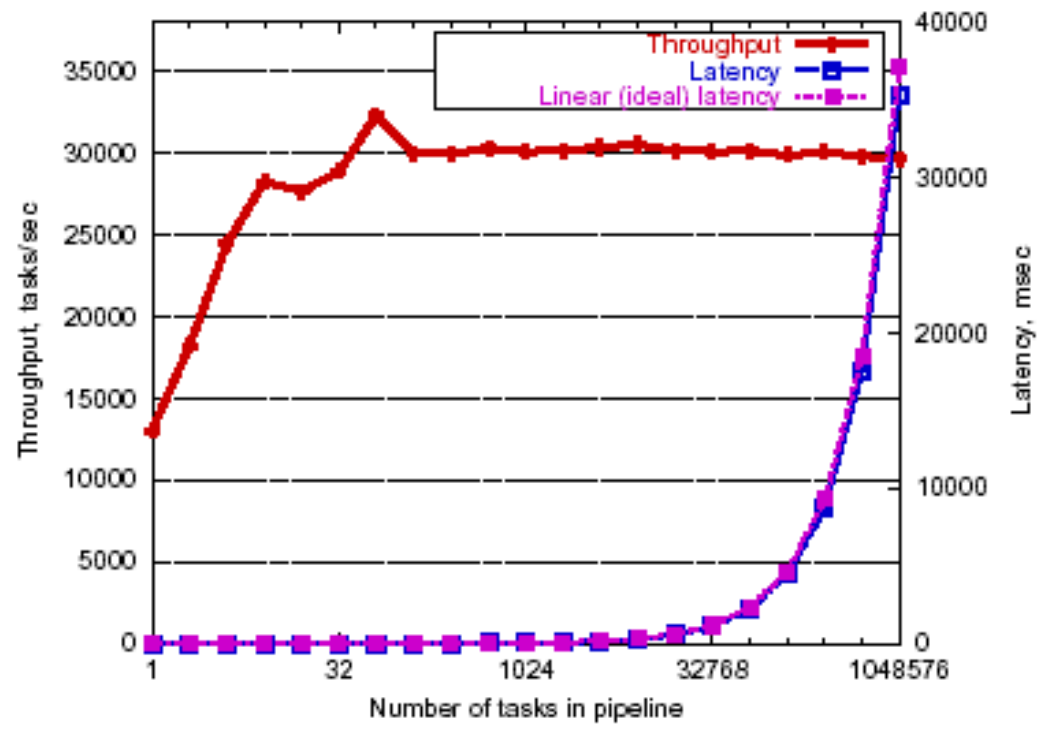

Threads vs. Events

- Events-based systems use fewer resources
 - Better performance (particularly scalability)
- Event-based systems harder to program
 - Have to avoid blocking at all cost
 - Block-structured programming doesn't work
 - How to do exception handling?
- In both cases, tuning is difficult

SEDA

- Mixture of models of threads and events
- Events, queues, and “pools of event handling threads”.
- Pools can be dynamically adjusted as need arises.

SEDA Stage

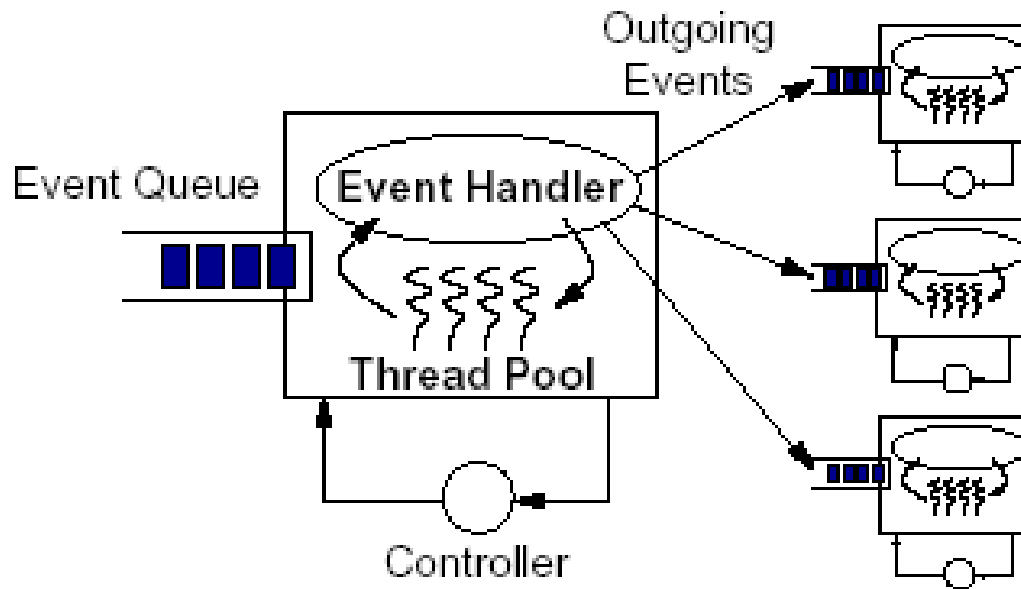

Best of both worlds

- Ease of programming of threads
 - Or even better
- Performance of events
 - Or even better
- Did we achieve Lauer and Needham's vision with SEDA?

Next Time

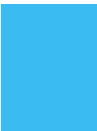
- Read and write review:
 - Check website for presentation schedule
 - Gossip miniproj
 - Do we need another getting started session?
 - Getting started session was today Tue, Sep 10.
 - Project Proposal due ~~this week, Thu, Sep 12~~, **Tue, Sep 17**
 - talk to me and other faculty and email and talk to me
 - Check website for updated schedule
- 

Next Time

- Read and write review:
 - **Required: The Performance of μ -Kernel-based Systems**, Hermann Härtig, Michael Hohmuth, Jochen Liedtke, Jean Wolter, and Sebastian Schönberg. 16th *ACM Symposium on Operating Systems Principles (SOSP)*, Oct 1997, pages 66—77.
<https://dl.acm.org/doi/10.1145/268998.266660>
 - **Optional: Mach: A new kernel foundation for UNIX development**, Mike Accetta, Robert Baron, William Bolosky, David Golub, Richard Rashid, Avadis Tevanian, and Michael Young. *Proceedings of the USENIX Summer Conference*, Atlanta, GA, 1986, pages 93—112.
<https://ieeexplore.ieee.org/abstract/document/109278>