

Parallelism, Multicore, and Synchronization

CS 3410

Computer Science

Cornell University

[K. Bala, A. Bracy, M. Martin, S. McKee, A. Roth E. Sirer, and H. Weatherspoon₁]

iClicker Question

Which of the following is trouble-free code?

```
A int *bubble()
{ int a;
  ...
  return &a;
}
```

```
C char *rubble()
{ char s[20];
  gets(s);
  return s;
}
```

```
B int *toil()
{ int *s;
  s = (int *)malloc(20);
  ...
  return s;
}
```

```
D int *trouble()
{ int *s;
  s = (int *)malloc(20);
  ...
  free(s);
  ...
  return s;
}
```

Evil things allowed by C

Don't ever write code like this!

Dangling pointers into freed heap mem

```
void some_function() {  
    int *x = malloc(1000);  
    int *y = malloc(2000);  
    free(y);  
    int *z = malloc(3000);  
    y[20] = 7;  
}
```

Dangling pointers into old stack frames

```
void f1() {  
    int *x = f2();  
    int y = *x + 2;  
}  
int *f2() {  
    int a = 3;  
    return &a;  
}
```

Performance Improvement 101

$$\frac{\text{seconds}}{\text{program}} = \frac{\text{instructions}}{\text{program}} \times \frac{\text{cycles}}{\text{instruction}} \times \frac{\text{seconds}}{\text{cycle}}$$

2 Classic Goals of Architects:

Clock period (Clock frequency)

Cycles per Instruction (IPC)

Clock frequencies have stalled

Darling of performance improvement for decades

Why is this no longer the strategy?

Hitting Limits:

- Pipeline depth
- Clock frequency
- Moore's Law & Technology Scaling
- Power

Improving IPC via ILP

You've seen:

Exploiting **Intra-instruction parallelism**:

Pipelining (decode A while fetching B)

You haven't seen:

Exploiting **Instruction Level Parallelism (ILP)**:

Multiple issue pipeline (2-wide, 4-wide, *etc.*)

- Statically detected by compiler (VLIW)
- Dynamically detected by HW

Dynamically Scheduled (OoO)

Static Multiple Issue

a.k.a. *Very Long Instruction Word (VLIW)*

Compiler groups instructions to be issued together

- Packages them into “issue slots”

How does HW detect and resolve hazards?

It doesn't. 😊 Compiler must avoid hazards

Example: Static Dual-Issue 32-bit MIPS

- Instructions come in pairs (64-bit aligned)
 - One ALU/branch instruction (or nop)
 - One load/store instruction (or nop)

MIPS with Static Dual Issue

Two-issue packets

- One ALU/branch instruction
- One load/store instruction
- 64-bit aligned
 - ALU/branch, then load/store
 - Pad an unused instruction with nop

Address	Instruction type	Pipeline Stages						
n	ALU/branch	IF	ID	EX	MEM	WB		
n + 4	Load/store	IF	ID	EX	MEM	WB		
n + 8	ALU/branch		IF	ID	EX	MEM	WB	
n + 12	Load/store		IF	ID	EX	MEM	WB	
n + 16	ALU/branch			IF	ID	EX	MEM	WB
n + 20	Load/store			IF	ID	EX	MEM	WB

Scheduling Example

Schedule this for dual-issue MIPS

```
Loop: lw    $t0, 0($s1)      # $t0=array element
      addu  $t0, $t0, $s2    # add scalar in $s2
      sw    $t0, 0($s1)      # store result
      addi  $s1, $s1, -4     # decrement pointer
      bne   $s1, $zero, Loop # branch $s1!=0
```

	ALU/branch	Load/store	cycle
Loop:	nop	lw \$t0, 0(\$s1)	1
	addi \$s1, \$s1, -4	nop	2
	addu \$t0, \$t0, \$s2	nop	3
	bne \$s1, \$zero, Loop	sw \$t0, 4(\$s1)	4

Clicker Question: What is the IPC of this machine?

(A) 0.8 (B) 1.0 (C) 1.25 (D) 1.5 (E) 2.0

(hint: think completion rates)

Techniques and Limits of Static Scheduling

Goal: larger instruction windows (to play with)

- Predication
- Loop unrolling
- Function in-lining
- Basic block modifications (superblocks, *etc.*)

Roadblocks

- Memory dependences (aliasing)
- Control dependences

Improving IPC via ILP

Exploiting Intra-instruction parallelism:

Pipelining (decode A while fetching B)

Exploiting Instruction Level Parallelism (ILP):

Multiple issue pipeline (2-wide, 4-wide, *etc.*)

- Statically detected by compiler (VLIW)
- **Dynamically detected by HW**

Dynamically Scheduled (OoO)

Dynamic Multiple Issue

aka SuperScalar Processor (c.f. Intel)

- CPU chooses multiple instructions to issue each cycle
- Compiler can help, by reordering instructions....
- ... but CPU resolves hazards

Improving IPC via ILP

Exploiting Intra-instruction parallelism:

Pipelining (decode A while fetching B)

Exploiting Instruction Level Parallelism (ILP):

Multiple issue pipeline (2-wide, 4-wide, *etc.*)

- Statically detected by compiler (VLIW)
- Dynamically detected by HW

Dynamically Scheduled (OoO)

Dynamic Scheduling

Even better: Speculation/Out-of-order Execution

- Execute instructions as early as possible
- Aggressive register renaming (indirection to the rescue!)
- Guess results of branches, loads, etc.
- Roll back if guesses were wrong
- Don't commit results until all previous insns committed

Effectiveness of OoO Superscalar

It was awesome, but then it stopped improving
Limiting factors?

- Programs dependencies
- Memory dependence detection → be conservative
 - e.g. Pointer Aliasing: `A[0] += 1; B[0] *= 2;`
- Hard to expose parallelism
 - Still limited by the fetch stream of the static program
- Structural limits
 - Memory delays and limited bandwidth
- Hard to keep pipelines full, especially with branches

Improving IPC via ~~ILP~~ TLP

Exploiting Thread-Level parallelism

Hardware multithreading to **improve utilization**:

- Multiplexing multiple threads on single CPU
- Sacrifices latency for throughput
- Single thread cannot fully utilize CPU? *Try more!*
- Three types:
 - Course-grain (has preferred thread)
 - Fine-grain (round robin between threads)
 - Simultaneous (hyperthreading)

What is a thread?

Process: multiple threads, code, data and OS state

Threads: concurrent computations that share the same address space

- **Share:** code, data, files
- **Do not share:** regs or stack

Thread Memory Layout

Thread 1

SP

PC

Thread 2

SP

PC

Thread 3

SP

PC

Stack 1

Stack 2

Stack 3

Data

Insns

Virtual
Address
Space

(Heap subdivided, shared, & not shown.)

Standard Multithreading Picture

Time evolution of issue slots

- Color = thread, white = no instruction

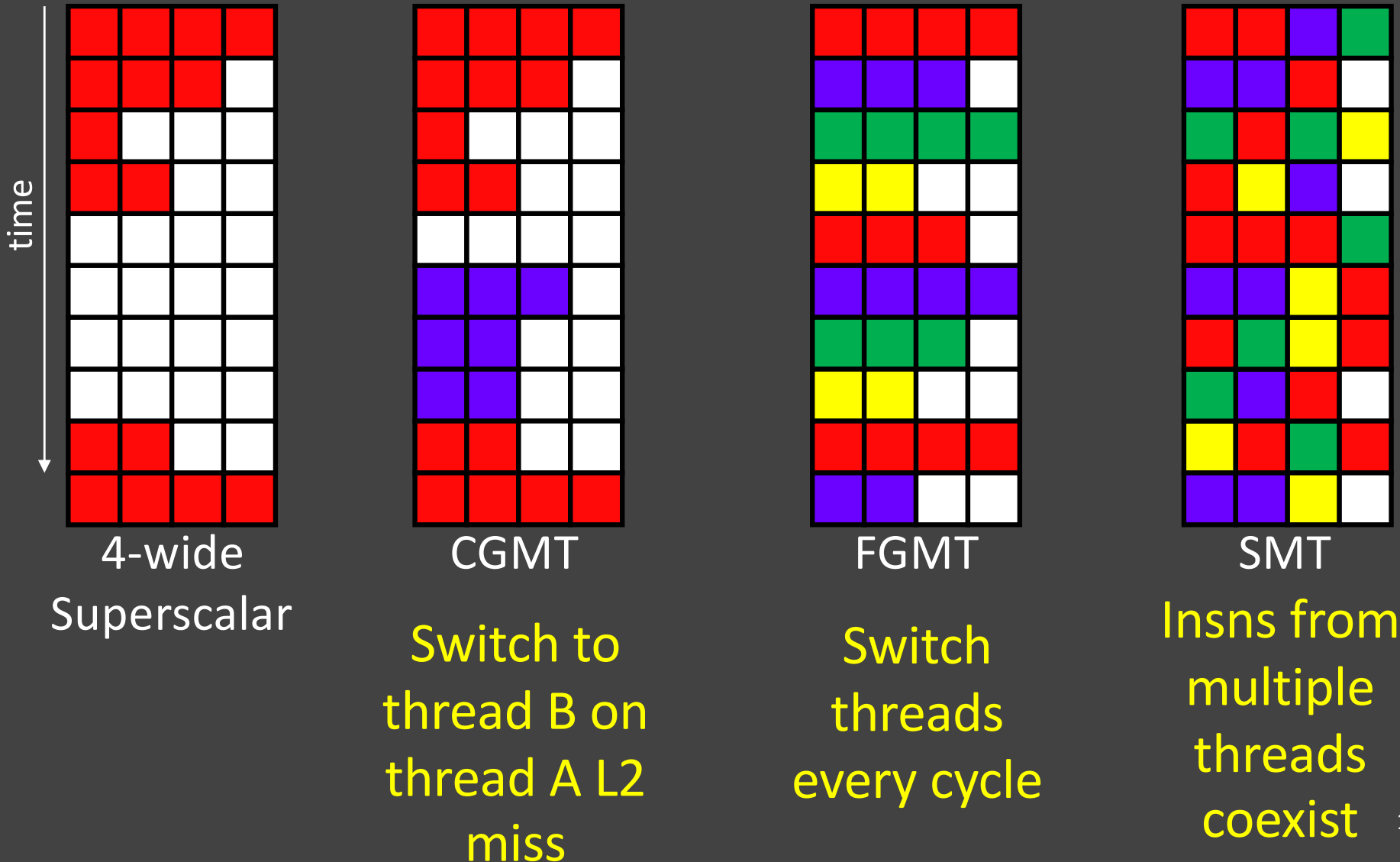

Power Efficiency

CPU	Year	Clock Rate	Pipeline Stages	Issue width	Out-of-order/ Speculation	Cores	Power
i486	1989	25MHz	5	1	No	1	5W
Pentium	1993	66MHz	5	2	No	1	10W
Pentium Pro	1997	200MHz	10	3	Yes	1	29W
P4 Willamette	2001	2000MHz	22	3	Yes	1	75W
UltraSparc III	2003	1950MHz	14	4	No	1	90W
P4 Prescott	2004	3600MHz	31	3	Yes	1	103W

Those simpler cores did something very right.

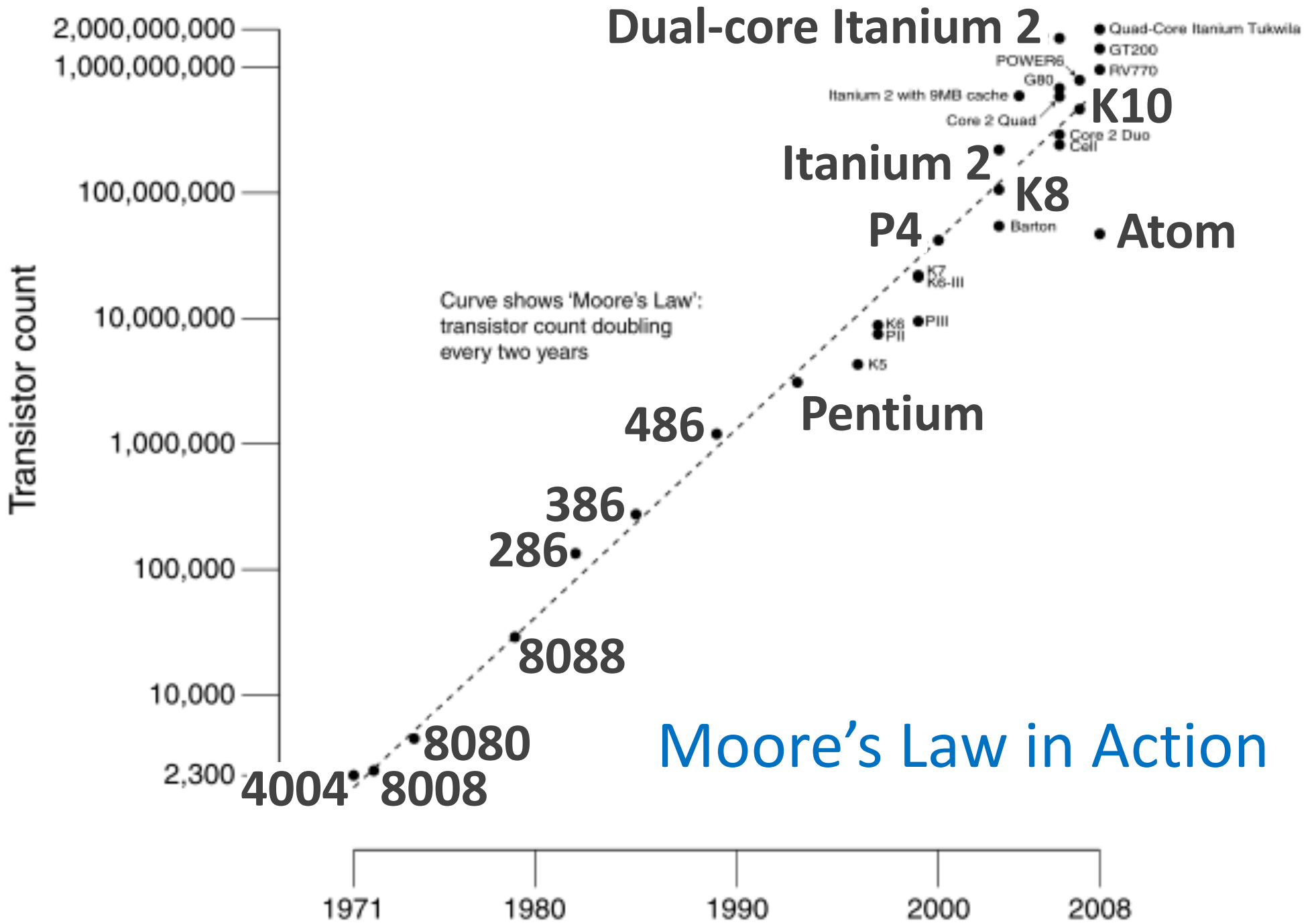

Unintended Side Effect: Power Limits

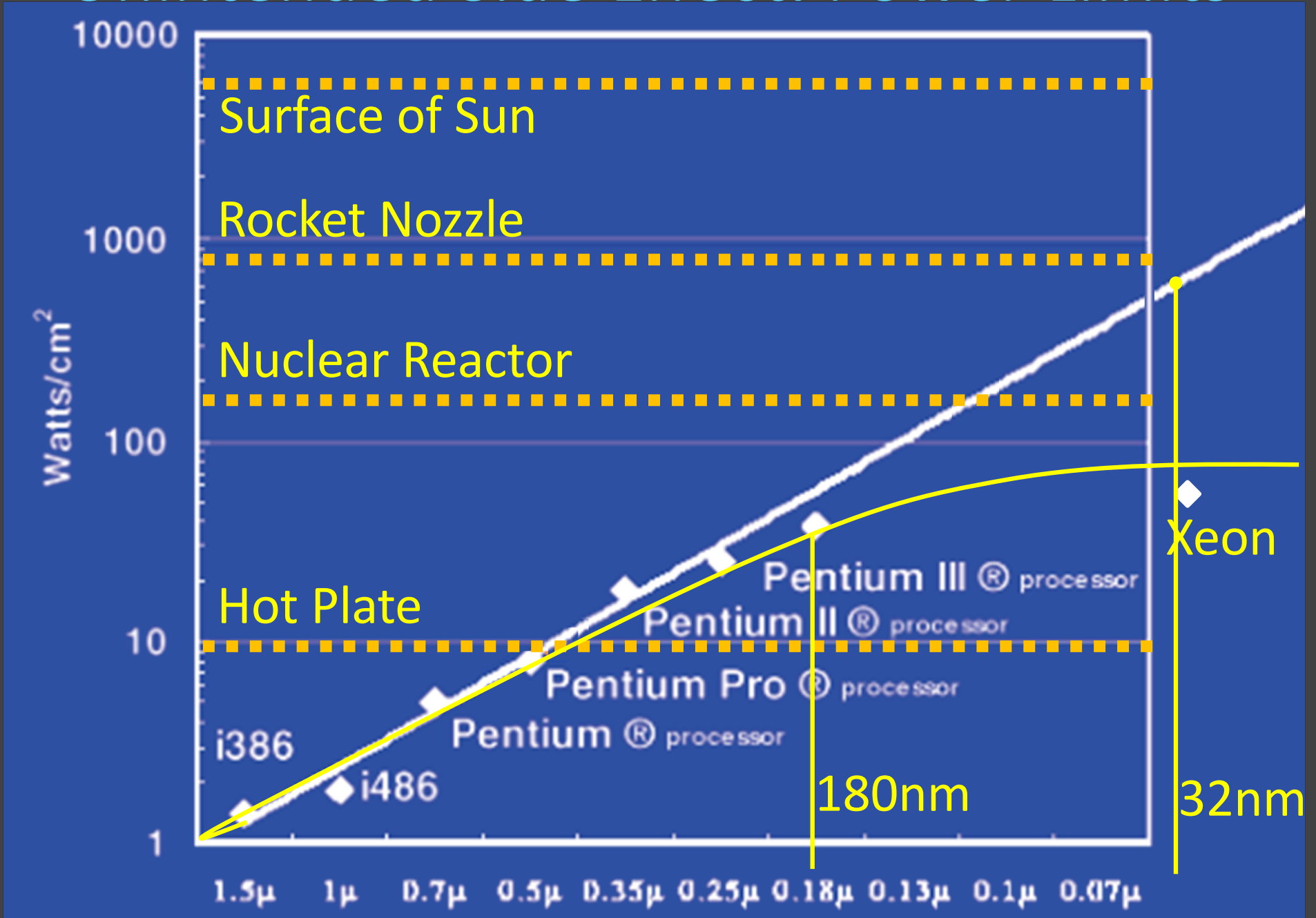

Power Wall

Power = capacitance * voltage² * frequency

In practice: Power ~ voltage³

Lower Frequency

Reducing voltage helps (a lot)

... so does reducing clock speed

Better cooling helps

The **power wall**

- We can't reduce voltage further
- We can't remove more heat

Why Multicore?

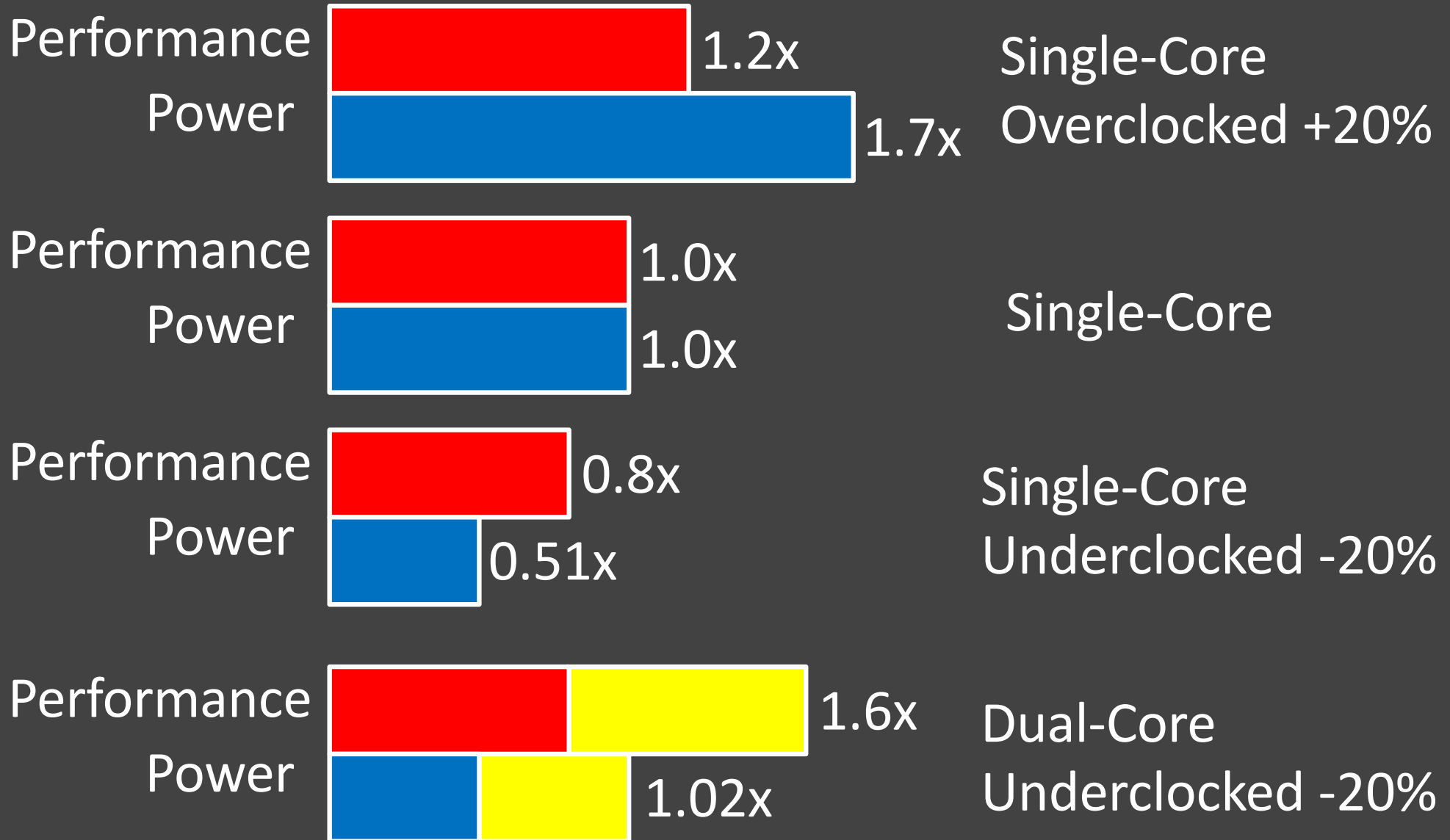

Power Efficiency

CPU	Year	Clock Rate	Pipeline Stages	Issue width	Out-of-order/ Speculation	Cores	Power
i486	1989	25MHz	5	1	No	1	5W
Pentium	1993	66MHz	5	2	No	1	10W
Pentium Pro	1997	200MHz	10	3	Yes	1	29W
P4 Willamette	2001	2000MHz	22	3	Yes	1	75W
UltraSparc III	2003	1950MHz	14	4	No	1	90W
P4 Prescott	2004	3600MHz	31	3	Yes	1	103W
Core	2006	2930MHz	14	4	Yes	2	75W
Core i5 Nehal	2010	3300MHz	14	4	Yes	1	87W
Core i5 Ivy Br	2012	3400MHz	14	4	Yes	8	77W
UltraSparc T1	2005	1200MHz	6	1	No	8	70W

Those simpler cores did something very right.

Parallel Programming

Q: So lets just all use multicore from now on!

A: Software must be written as parallel program

Multicore difficulties

- Partitioning work
- Coordination & synchronization
- Communications overhead
- How do you write parallel programs?
... without knowing exact underlying architecture?

Work Partitioning

Partition work so all cores have something to do

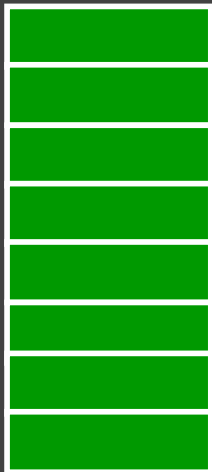

Load Balancing

Need to partition so all cores are actually working

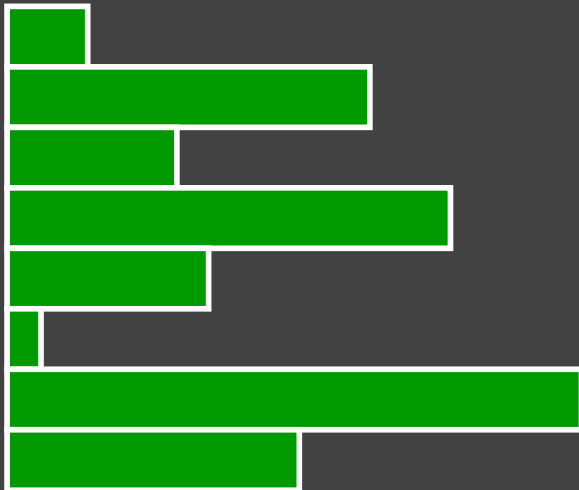

Amdahl's Law

If tasks have a **serial part** and a **parallel part**...

Example:

step 1: divide input data into n pieces

step 2: do work on each piece

step 3: combine all results

Recall: **Amdahl's Law**

As number of cores increases ...

- time to execute parallel part? **goes to zero**
- time to execute serial part? **Remains the same**
- *Serial part eventually dominates*

Amdahl's Law

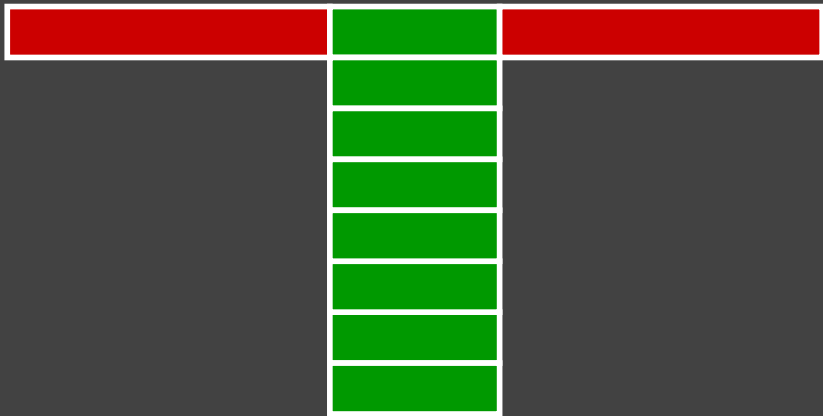
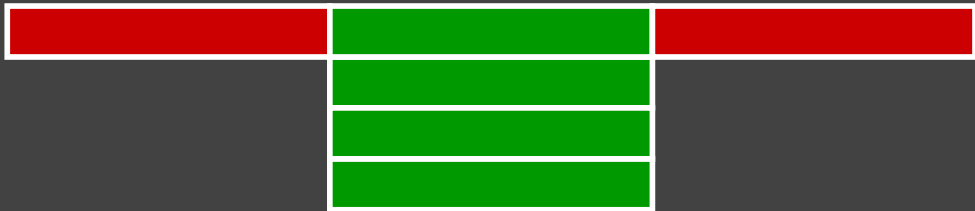

Parallelism is a necessity

Necessity, not luxury

Power wall

Not easy to get performance out of

Many solutions

Pipelining

Multi-issue

Multithreading

Multicore

Parallel Programming

Q: So lets just all use multicore from now on!

A: Software must be written as parallel program

Multicore difficulties

- Partitioning work
- **Coordination & synchronization**
- Communications overhead
- How do you write parallel programs?
... without knowing exact underlying architecture?

Parallelism & Synchronization

Cache Coherency

- Processors cache *shared* data → they see different (**incoherent**) values for the *same* memory location

Synchronizing parallel programs

- Atomic Instructions
- HW support for synchronization

How to write parallel programs

- Threads and processes
- Critical sections, race conditions, and mutexes

Shared Memory Multiprocessors

Shared Memory Multiprocessor (SMP)

- Typical (today): 2 – 4 processor dies, 2 – 8 cores each
- Hardware provides *single physical address* space for all processors

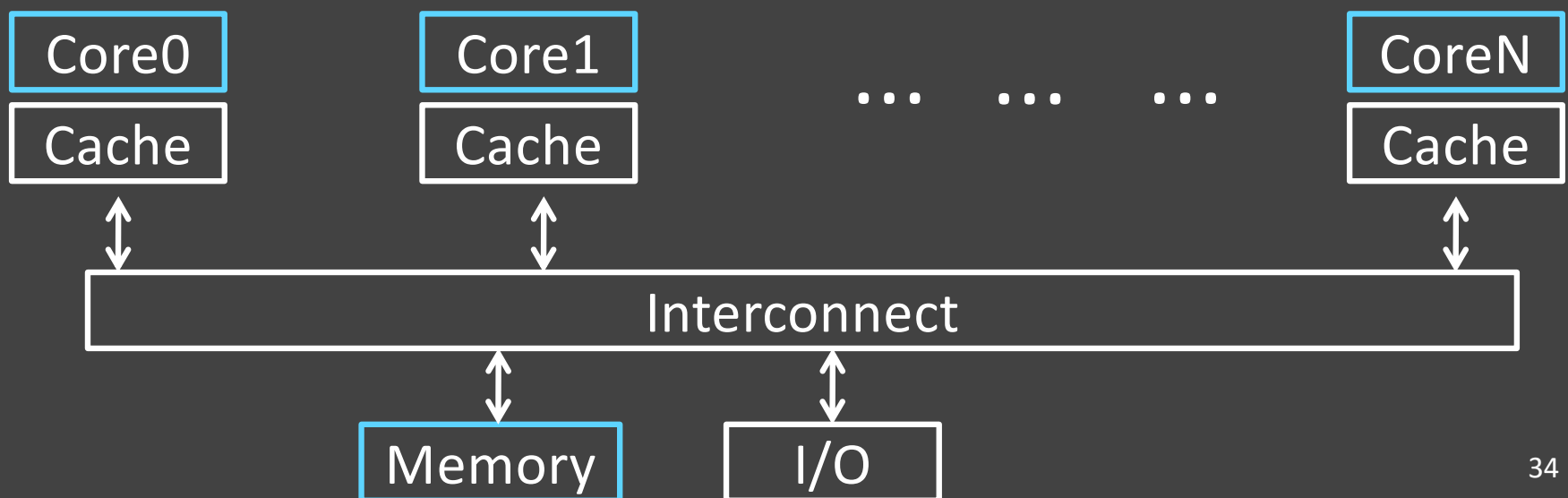

Cache Coherency Problem

Thread A (on Core0)
for(int i = 0, i < 5; i++) {
 x = x + 1;
}

Thread B (on Core1)
for(int j = 0; j < 5; j++) {
 x = x + 1;
}

What will the value of **x** be after both loops finish?

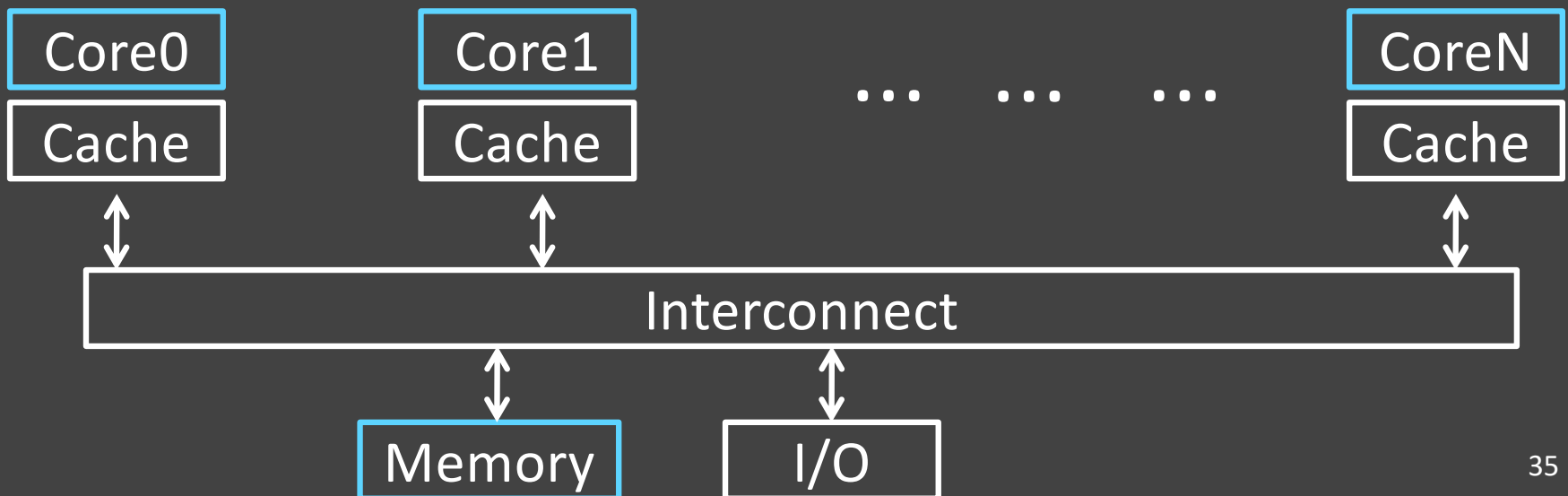

Cache Coherency Problem

Thread A (on Core0)

```
for(int i = 0, i < 5; i++) {  
    x = x + 1;  
}
```

Thread B (on Core1)

```
for(int j = 0; j < 5; j++) {  
    x = x + 1;  
}
```

What will the value of x be after both loops finish?

(x starts as 0)

- a) 6
- b) 8
- c) 10
- d) Could be any of the above
- e) Couldn't be any of the above

Cache Coherency Problem, WB \$

Thread A (on Core0)

```
for(int i = 0, i < 5; i++) {
```

```
$t0=0  LW $t0, addr(x)
```

```
$t0=1  ADDIU $t0, $t0, 1
```

```
x=1    SW $t0, addr(x)
```

```
}
```

Thread B (on Core1)

```
for(int j = 0; j < 5; j++) {
```

```
$t0=0  LW $t0, addr(x)
```

```
$t0=1  ADDIU $t0, $t0, 1
```

```
x=1    SW $t0, addr(x)
```

```
}
```

Problem!

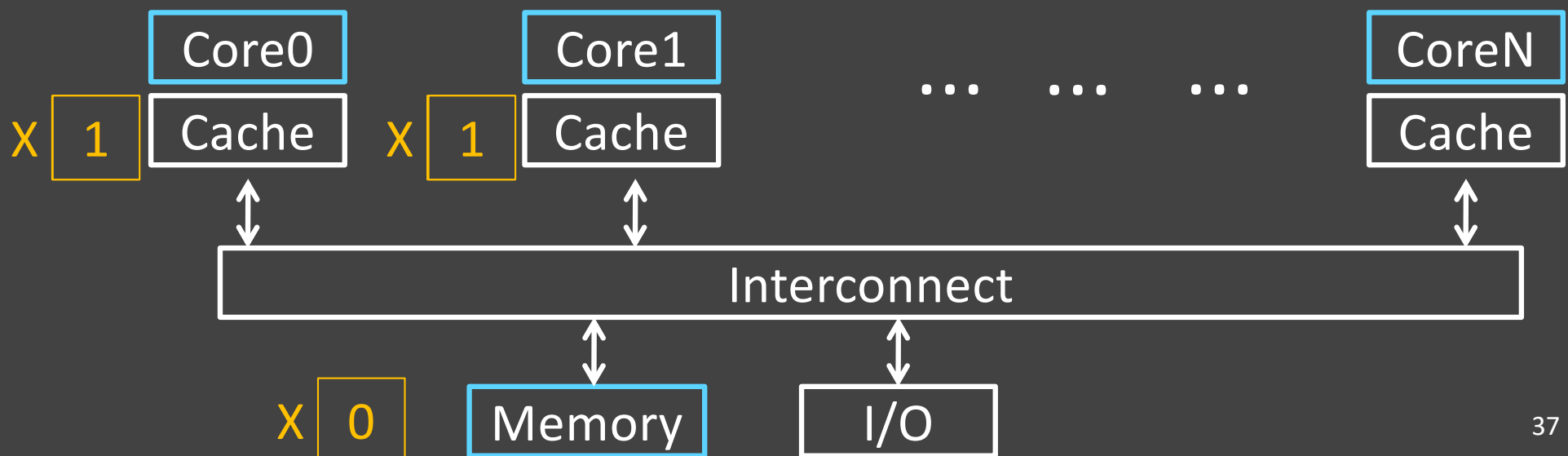

Not just a problem for Write-Back Caches

Executing on a write-thru cache:

Time step	Event	CPU A's cache	CPU B's cache	Memory
0				0
1	CPU A reads X	0		0
2	CPU B reads X	0	0	0
3	CPU A writes 1 to X	1	0	1

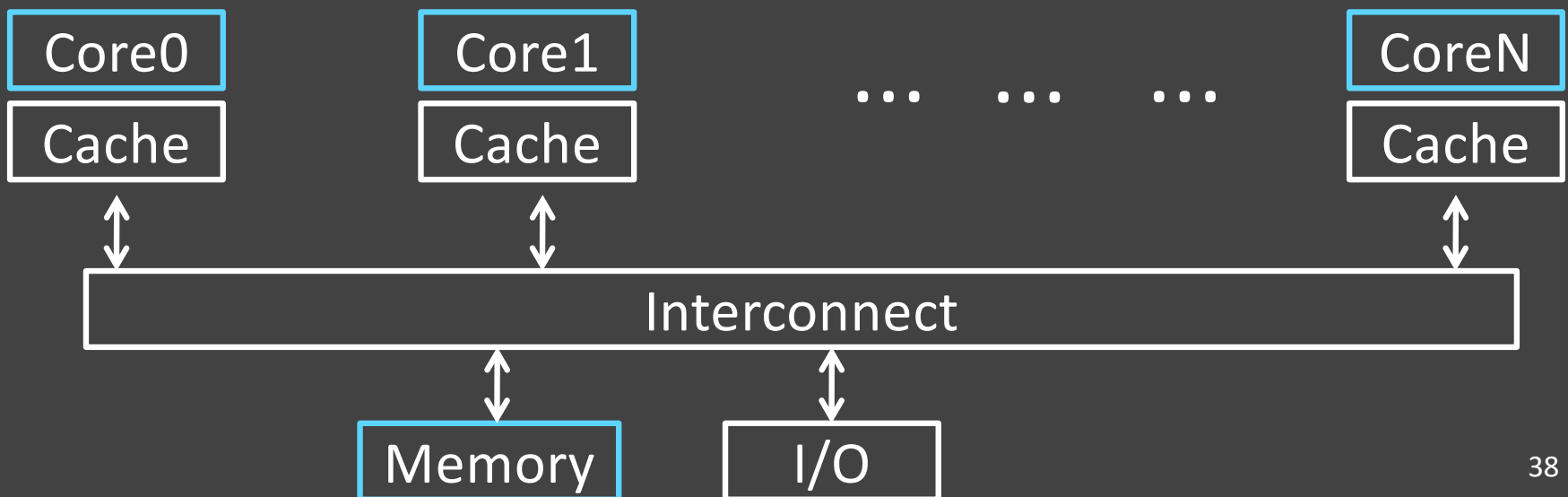

Two issues

Coherence

- What values can be returned by a read
- Need a globally uniform (consistent) view of a single memory location

Solution: Cache Coherence Protocols

Consistency

- When a written value will be returned by a read
- Need a globally uniform (consistent) view of *all memory locations relative to each other*

Solution: Memory Consistency Models

Hardware Cache Coherence

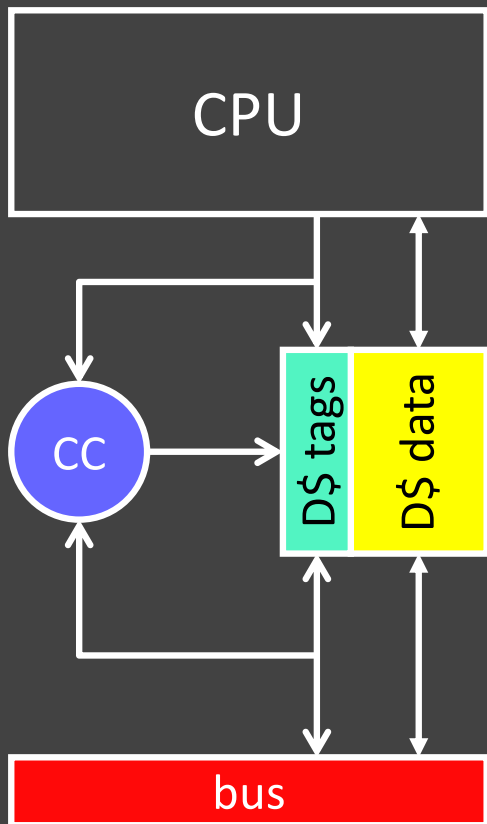

Coherence

- all copies have same data at all times

Coherence controller:

- Examines bus traffic (addresses and data)
- Executes **coherence protocol**
 - What to do with local copy when you see different things happening on bus

Three processor-initiated events

- **Ld**: load
- **St**: store
- **WB**: write-back

Two remote-initiated events

- **LdMiss**: read miss from *another* processor
- **StMiss**: write miss from *another* processor

VI Coherence Protocol

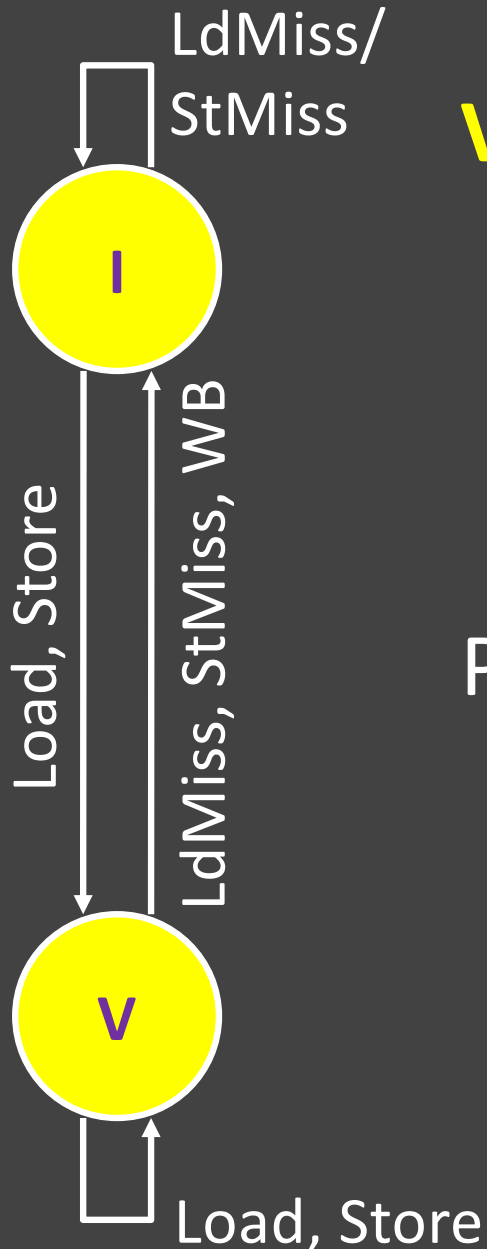

VI (valid-invalid) protocol:

- Two states (per block in cache)
 - V (valid): have block
 - I (invalid): don't have block
 - + Can implement with valid bit

Protocol diagram (left)

- If *you* load/store a block: transition to V
- If anyone *else* wants to read/write block:
 - Give it up: transition to I state
 - Write-back if your own copy is dirty

VI Protocol (Write-Back Cache)

Thread A

```
lw t0, 0(r3),
ADDIU $t0,$t0,1
sw t0,0(r3)
```

Thread B

```
lw t0, 0(r3)
ADDIU $t0,$t0,1
sw t0,0(r3)
```

CPU0	CPU1	Mem
		0
V:0		0
V:1		0
I:	V:1	1
	V:2	1

lw by Thread B generates an “other load miss” event (LdMiss)

- Thread A responds by sending its dirty copy, transitioning to I

VI Coherence Question

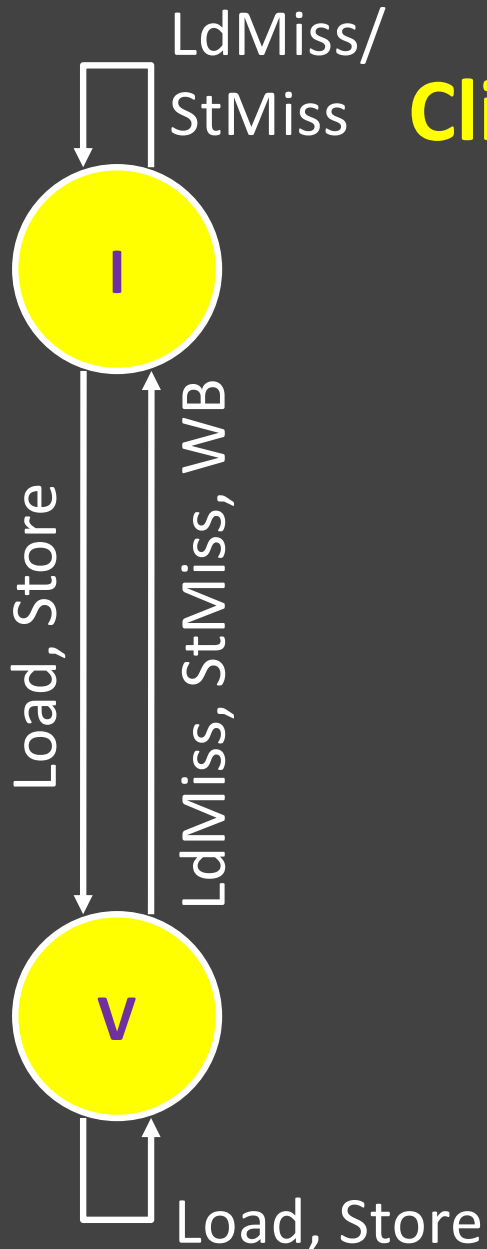

Clicker Question:

Core A loads x into a register

Core B wants to load x into a register

What happens?

- (A) they can both have a copy of X in their cache
- (B) A keeps the copy
- (C) B steals the copy from A, and this is an efficient thing to do
- (D) B steals the copy from A, and this is a sad shame
- (E) B waits until A kicks X out of its cache, then it can complete the load

VI → MSI

VI protocol is inefficient

- Only one cached copy allowed in entire system
- Multiple copies can't exist even if read-only
 - Not a problem in example
 - Big problem in reality

MSI (modified-shared-invalid)

- Fixes problem: splits "V" state into two states
 - M (modified): local dirty copy
 - S (shared): local clean copy
- Allows **either**
 - Multiple read-only copies (S-state) **--OR--**
 - Single read/write copy (M-state)

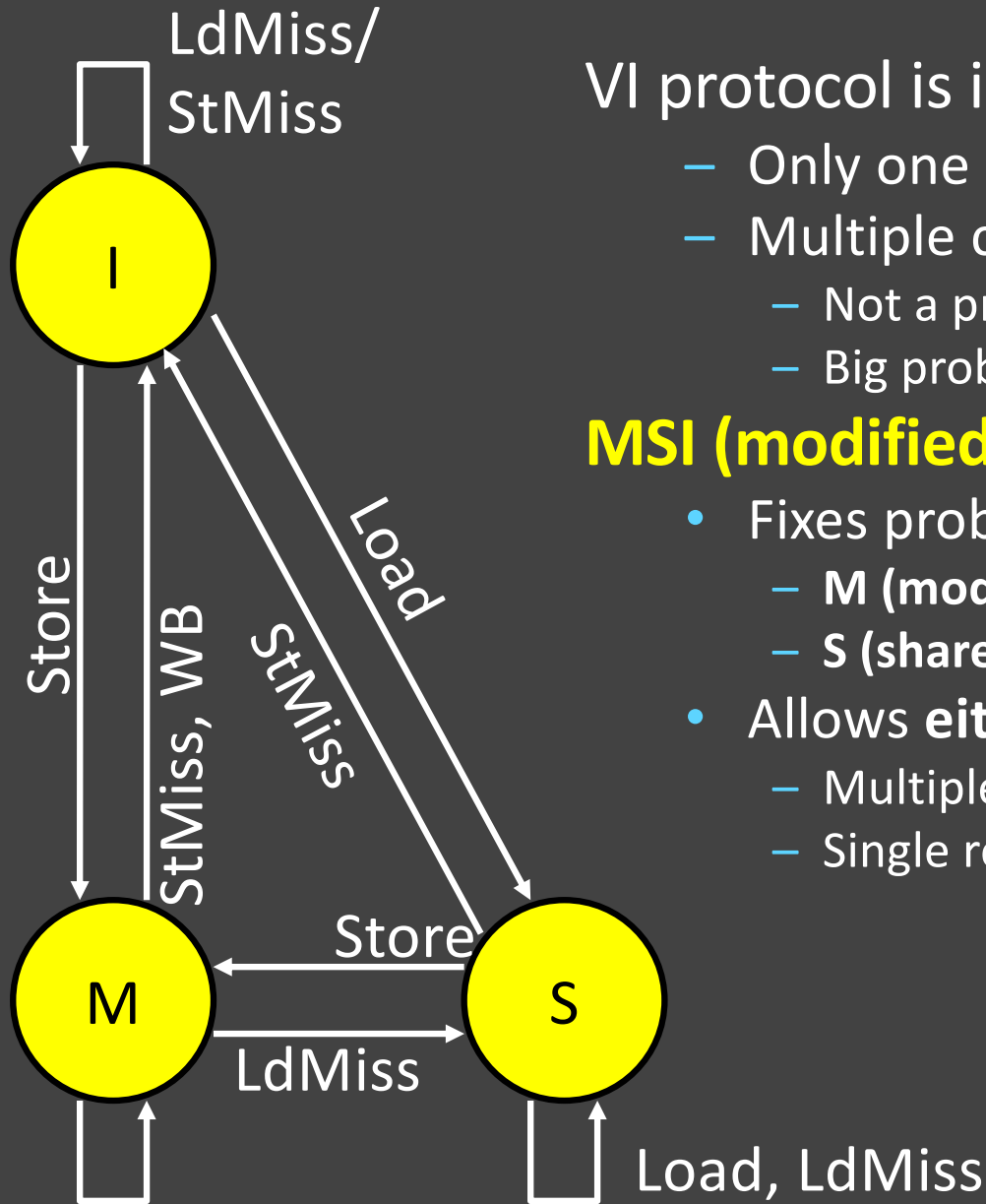

Load, Store

MSI Protocol (Write-Back Cache)

Thread A

```
lw t0, 0(r3),
ADDIU $t0,$t0,1
sw t0,0(r3)
```

Thread B

```
lw t0, 0(r3),
ADDIU $t0,$t0,1
sw t0,0(r3)
```

CPU0	CPU1	Mem
		0
S:0		0
M:1		0
S:1	S:1	1
I:	M:2	1

lw by Thread B generates a “other load miss” event (LdMiss)

- Thread A responds by sending its dirty copy, transitioning to S

sw by Thread B generates a “other store miss” event (StMiss)

- Thread A responds by transitioning to I

Cache Coherence and Cache Misses

Coherence introduces two new kinds of cache misses

- **Upgrade miss**
 - On stores to read-only blocks
 - Delay to acquire write permission to read-only block
- **Coherence miss**
 - Miss to a block evicted by another processor's requests

Making the cache larger...

- Doesn't reduce these type of misses
- As cache grows large, these sorts of misses dominate

False sharing

- Two or more processors sharing parts of the same block
- But *not* the same bytes within that block (no actual sharing)
- **Creates pathological “ping-pong” behavior**
- **Careful data placement may help, but is difficult**

More Cache Coherence

In reality: many coherence protocols

- Snooping: VI, MSI, MESI, MOESI, ...
 - But Snooping doesn't scale
- Directory-based protocols
 - Caches & memory record blocks' sharing status in directory
 - Nothing is free → directory protocols are slower!

Cache Coherency:

- requires that **reads** return most recently **written** value
- Is a hard problem!

Clicker Question

A single core machine that supports multiple threads can experience a coherence miss.

A. True

B. False

C. Cannot be answered with the information given

Are We Done Yet?

Thread A

`lw t0, 0(r3)`

`ADDIU $t0, $t0, 1`

`sw t0, 0(x)`

Thread B

`lw t0, 0(r3)`

`ADDIU $t0, $t0, 1`

`sw t0, 0(x)`

CPU0	CPU1	Mem
		0
S:0		0
S:0	S:0	0
I:	M:1	0
M:1	I:	1

What just happened???

Is MSI Cache Coherency Protocol Broken??

Clicker Question

The Previous example shows us that

- a) Caches can be incoherent even if there is a coherence protocol.
- b) The MSI protocol is not rich enough to support coherence for multi-threaded programs
- c) Coherent caches are not enough to guarantee expected program behavior.
- d) Multithreading is just a really bad idea.
- e) All of the above

Programming with threads

Within a thread: execution is sequential

Between threads?

- No ordering or timing guarantees
- Might even run on different cores at the same time

Problem: hard to program, hard to reason about

- Behavior can depend on subtle timing differences
- Bugs may be impossible to reproduce

Cache coherency is necessary but **not** sufficient...

Need explicit synchronization to make guarantees about concurrent threads!

Race conditions

Timing-dependent error involving access to shared state

Race conditions depend on how threads are scheduled

- i.e. who wins “races” to update state

Challenges of Race Conditions

- Races are intermittent, may occur rarely
- Timing dependent = small changes can hide bug

Program is correct *only* if *all possible* schedules are safe

- Number of possible schedules is huge
- Imagine adversary who switches contexts at worst possible time

Hardware Support for Synchronization

Atomic **read & write** memory operation

- Between read & write: *no writes to that address*

Many atomic hardware primitives

- **test and set** (x86)
- **atomic increment** (x86)
- **bus lock prefix** (x86)
- **compare and exchange** (x86, ARM deprecated)
- **linked load / store conditional** (pair of insns)
(MIPS, ARM, PowerPC, DEC Alpha, ...)

Synchronization in MIPS

Load linked: `LL rt, offset(rs)`

“I want the value at address X. Also, start monitoring any writes to this address.”

Store conditional: `SC rt, offset(rs)`

“If no one has changed the value at address X since the LL, perform this store and tell me it worked.”

- Data at location **has not changed** since the LL?
 - **SUCCESS:**
 - Performs the store
 - Returns 1 in rt
- Data at location **has changed** since the LL?
 - **FAILURE:**
 - Does not perform the store
 - Returns 0 in rt

Using LL/SC to create Atomic Increment

Load linked: LL rt, offset(rs)

Store conditional: SC rt, offset(rs)

i++



```
LW $t0, 0($s0)
ADDIU $t0, $t0, 1
SW $t0, 0($s0)
```



atomic(i++)



```
try: LL $t0, 0($s0)
      ADDIU $t0, $t0, 1
      SC $t0, 0($s0)
      BEQZ $t0, try
```

Value in memory changed between LL and SC ?

→ SC returns 0 in \$t0 → retry

Atomic Increment in Action

Load linked: LL \$t0, offset(\$s0)

Store conditional: SC \$t0, offset(\$s0)

Time	Thread A	Thread B	Thread A \$t0	Thread B \$t0	Mem [\$s0]
0					0
1	try: LL \$t0, 0(\$s0)		0		0
2		try: LL \$t0, 0(\$s0)		0	0
3	ADDIU \$t0, \$t0, 1		1	0	0
4		ADDIU \$t0, \$t0, 1	1	1	0
5	SC \$t0, 0(\$s0)		1	1	1
6	BEQZ \$t0, try		1	1	1
7		SC \$t0, 0(\$s0)	1	0	1
8		BEQZ \$t0, try	1	0	1

Success!

Failure!

Critical Sections

Create atomic version of every instruction? **NO**

Does not scale *or solve the problem*

To eliminate races: identify *Critical Sections*

- only one thread can be in
- Contending threads must wait to enter

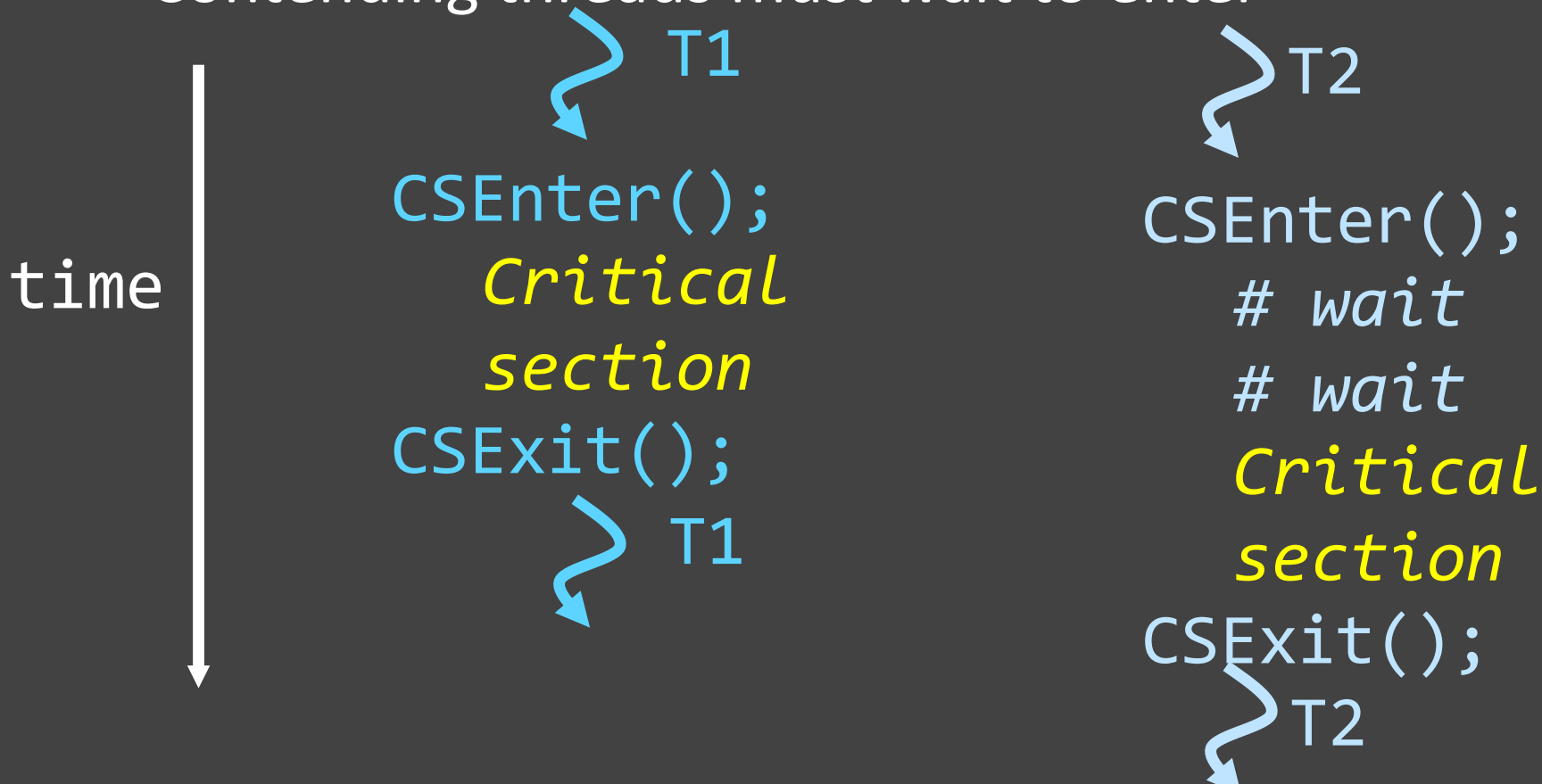

Mutual Exclusion Lock (Mutex)

Implementation of CSEnter and CSExit

- Only one thread can hold the lock at a time
“I have the lock”

Mutex from LL and SC

```
m = 0;
mutex_lock(int *m) {
    test_and_set: LI $t0, 1
                  LL $t1, 0($a0)
                  BNEZ $t1, test_and_set
                  SC $t0, 0($a0)
                  BEQZ $t0, test_and_set
}

mutex_unlock(int *m) {
    SW $zero, 0($a0)
}
```

This is called a
Spin lock
aka **spin waiting**

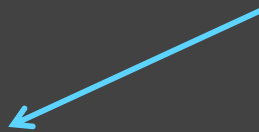

2 threads attempt to grab the lock

mutex_lock(int *m)

Time	Thread A	Thread B	ThreadA		ThreadB		Mem M[\$a0]
			\$t0	\$t1	\$t0	\$t1	
0							0
1	try: LI \$t0, 1	try: LI \$t0, 1	1		1		0
2	LL \$t1, 0(\$a0)	LL \$t1, 0(\$a0)	1	0	1	0	0
3	BNEZ \$t1, try	BNEZ \$t1, try	1	0	1	0	0
4		SC \$t0, 0 (\$a0)			1	0	1
5	SC \$t0, 0(\$a0)		0	0	1	0	1
6	BEQZ \$t0, try	BEQZ \$t0, try	0	0	1	0	1
7	try: LI \$t0, 1	Critical section					

Failure!

Success!

Producer/Consumer Example (1)

```
// invariant:  
// data in A[h .. t-1]  
char A[100];  
int h = 0, t = 0;  
  
// producer: add to tail if room  
void put(char c) {  
    A[t] = c;  
    t = (t+1)%n;  
}  
  
// consumer: take from head  
char get() {  
    while (t == h) { };  
    char c = A[h];  
    h = (h+1)%n;  
    return c;  
}
```

Goal: enforce data structure invariants

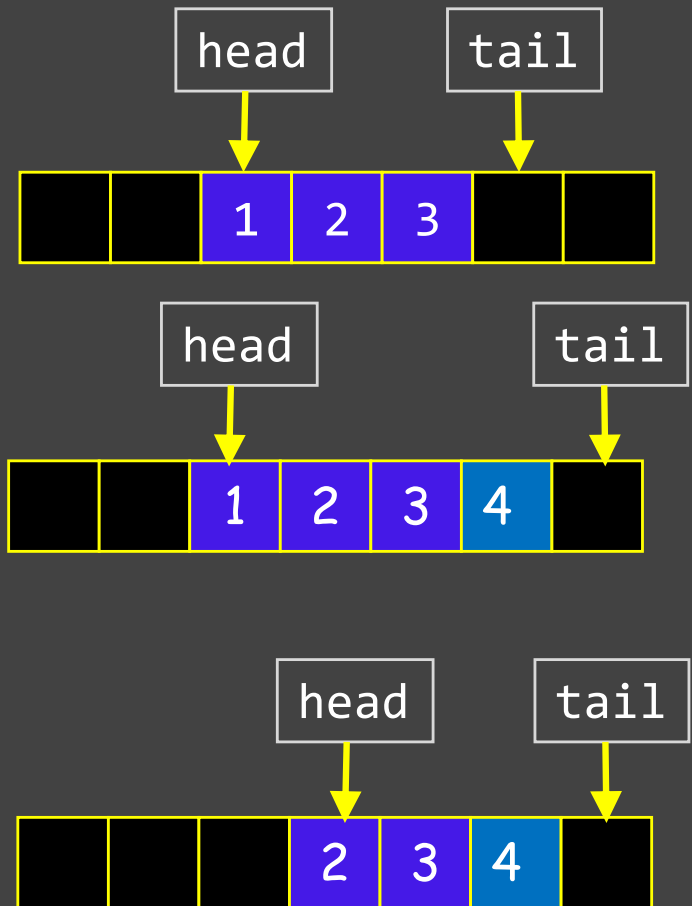

Producer/Consumer Example (2)

```
// invariant:  
// data in A[h .. t-1]  
char A[100];  
int h = 0, t = 0;
```

```
// producer: add to tail if room
```

```
void put(char c) {  
    A[t] = c;  
    t = (t+1)%n;  
}
```

```
// consumer: take from head
```

```
char get() {  
    while (t == h) { };  
    char c = A[h];  
    h = (h+1)%n;  
    return c;  
}
```

Goal: enforce data structure invariants

Clicker Q:

What's wrong here?

- a) Will lose update to t and/or h
- b) Invariant is not upheld
- c) Will produce if full
- d) Will consume if empty
- e) All of the above

Producer/Consumer Example (3)

```
// invariant:  
// data in A[h ... t-1]  
char A[100];  
int h = 0, t = 0;
```

```
// producer: add to tail if room
```

```
void put(char c) {  
    A[t] = c;  
    t = (t+1)%n;    ←  
}
```

```
// consumer: take from head
```

```
char get() {  
    while (t == h) { }; ←  
    char c = A[h];  
    h = (h+1)%n;    ←  
    return c;  
}
```

Goal: enforce data structure invariants

What's wrong here?

- Could miss an update to t or h
- **Breaks invariants:** only produce if not full, only consume if not empty
→ *Need to synchronize access to shared data*

Producer/Consumer Example (4)

```
// invariant:
// data in A[h ... t-1]
char A[100];
int h = 0, t = 0;

// producer: add to tail if room
void put(char c) {
    A[t] = c; ← acquire-lock()
    t = (t+1)%n; ← release-lock()
}

// consumer: take from head
char get() {
    ← acquire-lock()
    while (t == h) { };
    char c = A[h];
    h = (h+1)%n;
    return c; ← release-lock()
}
```

Goal: enforce data structure invariants

Rule of thumb:
all access & updates that can affect the invariant become critical sections

Does this fix work?

Language-level Synchronization

Lots of synchronization variations...

Reader/writer locks

- Any number of threads can hold a read lock
- Only one thread can hold the writer lock

Semaphores

- N threads can hold lock at the same time

Monitors

- Concurrency-safe data structure with 1 mutex
- All operations on monitor acquire/release mutex
- One thread in the monitor at a time