

# CS4450 Problem Set #2

## 1 Deeper Understanding of Queueing Delays

Consider the network shown below.

- The length of A-C, B-C and C-D links are all equal to  $6 \times 10^8$  m.
- The bandwidth of link A-C is equal to  $B_1 = 500$  bits per second.
- The bandwidth of link B-C is equal to  $B_2 = 250$  bits per second.
- The bandwidth of link C-D is equal to  $B_3 = 250$  bits per second.
- Speed of light =  $3 \times 10^8$  m/s.
- Transmission delay = packet size / bandwidth.
- Propagation delay = length of the link / speed of light.
- Both A and B have 4 packets each to be sent to destination D.
- Ignore all processing times and assume store-and-forward model.
- For any packet  $p$ , queueing delay at node C is computed as the time between C receiving the last bit of  $p$  and starting to transmit the first bit of  $p$ . That is, if C receives the last bit of  $p$  at time  $t$ , and starts transmitting the first bit of  $p$  at time  $t'$ , then queueing delay for packet  $p$  at node C is equal to  $(t' - t)$ .
- For this problem, assume packet size refers to size of packet headers and payload combined. That is, if packet headers are of size  $h$ , and payload is of size  $p$ , then packet size is  $h+p$ .

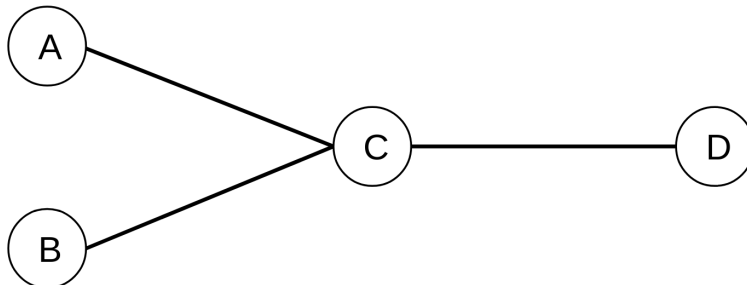

- Suppose A is the only one transmitting packets (to destination D) and let size of each packet be 1000 bits. For each packet sent by A, write down the queueing delay at C.

packet	Queueing Delay
1	
2	
3	
4	

- Suppose B is the only one transmitting packets (to destination D) and let size of each packet be 1000 bits. For each packet sent by B, write down the queueing delay at C.

packet	Queueing Delay
1	
2	
3	
4	

- Now, suppose both nodes A and B are transmitting packets (to destination D), and the size of each packet is equal to 1000 bits. Assume that both A and B start transmitting four packets at the same time, and that all packets from a node are transmitted immediately one after another. Suppose node C always transmits packets in a first-come first-serve order, that is, if node C has fully received two packets, one at time  $T_1$  and one at time  $T_2$  ( $T_2 > T_1$ ), then node C will transmit the packet at  $T_1$  before it transmits the packet received at  $T_2$ . For each of the packets sent by A and B, write down the queueing delay at C.

A packets	Queueing Delay
1	
2	
3	
4	

B packet	Queueing Delay
1	
2	
3	
4	

## 2 Deeper Understanding of Circuit versus Packet Switching

You have been hired to design a network at one of the largest network providers in the world. They want a topology as shown in the figure below, and want to maximize the utilization of link  $N_1 - N_2$ . You have been told the following constraints for the design:

- The units in this problem are not important, but in case you need it, all bandwidths are in bits/second and all latencies are in seconds.
- The bandwidth for link  $N_1 - N_2$  is  $B_1 = 1000$ ; also let  $B_2 = 500$ . The propagation delay for all links is 1 second. Assume that transmission and processing delays are zero.
- All nodes and links in the network will be built using a hypothetical material that guarantees failure-free operations. Also, assume that nodes have infinitely large buffers, so that no data will ever be dropped.
- The network will run two applications—A1 and A2—with demands shown in the figure.
  - A1 starts at time 0, runs at node  $s_1$ , and sends data to destination  $d_1$ .
  - A2 starts at time 10, runs at node  $s_2$ , and sends data to destination  $d_2$ .
  - The applications are not latency-sensitive, and only require high bandwidth.
  - Once started, applications never finish.
  - Both A1 and A2 are applications that can work with any quantity of bandwidth allocated to them; that is, if demand is  $X$  and they are allocated bandwidth  $Y < X$ , the application will still work. The difference of demand and bandwidth allocated is only reflected in the user-perceived quality of applications, and is **not** carried over to the future.
- You are allowed to use the following implementation of circuit switching. When an application starts, it sends a reservation request of the form {source, destination, bandwidth-request}. Upon receiving a request {source, destination, bandwidth-request= $R$ }, each node  $u$  in the network reserves bandwidth equal to  $R_u = \min\{R, \text{available bandwidth of link toward the destination}\}$ , updates the request to {source, destination, bandwidth-request= $R_u$ }, and forwards the request to the next node toward the destination. When the request reaches the destination, application has a circuit reserved with bandwidth equal to the third parameter in the request. Applications set up circuit only once. Applications can use bandwidth equal to the minimum of their reserved bandwidth and their demand.
- You are allowed to use the following implementation of packet switching. Each application sends data using 800 bit packet payloads, and 200 bit packet headers. Only payload bits contribute to the utilization.

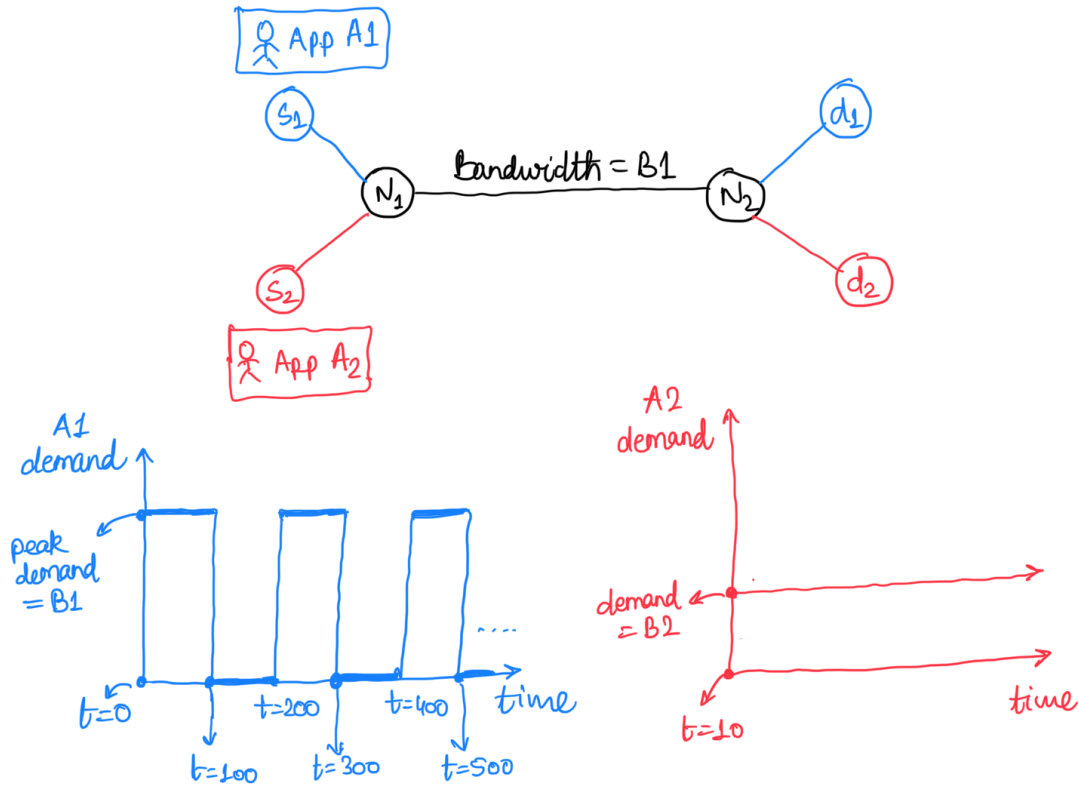

1. Suppose the bandwidths for all links is equal to  $B_1$ . The bandwidth demands for  $A_1$  and  $A_2$  are as shown in the figure. Would you design the network using circuit switching or packet switching? Why?
2. Suppose the bandwidths for all links is  $B_1$ . Show bandwidth demands for  $A_1$  and  $A_2$  for which you will always prefer circuit-switched network design over packet-switched network design. Give a reason why.
3. Now suppose you are forced to choose a different implementation of packet-switched networks, where all packets will be sent with a payload size of 100 bits and header size of 1000bits. The bandwidths for all links is equal to  $B_1$ . The bandwidth demands for  $A_1$  and  $A_2$  are as shown in the figure. Would you design the network using circuit switching or packet switching? Why?

### 3 CSMA/CD: Random Access

Let  $A$  and  $B$  be two stations attempting to transmit on an Ethernet. Each has a steady queue of frames ready to send;  $A$ 's frames are denoted  $A_1, A_2, \dots$ , and  $B$ 's are defined similarly.

Recall the random access protocol discussed in class. In case of a collision,  $A$  and  $B$  back off for  $d \times T$  time where  $T$  is the back off unit time and  $d \in D = \{0, \dots, 2^k - 1\}$ , where  $k$  is the number of collisions so far. You can think of selecting a  $d$  from  $D$  as choosing a time slot to transmit the packet from  $2^k$  future slots.

Suppose  $A$  and  $B$  simultaneously attempt to send their first frame, collide, and happen to choose back off times of  $0 \times T$  and  $1 \times T$ , respectively, meaning  $A$  wins the race and transmits  $A_1$  while  $B$  waits.

- a) At the end of the first transmission,  $B$  will attempt to retransmit  $B_1$  while  $A$  will attempt to transmit  $A_2$ . These attempts will collide. Now  $A$  will choose a waiting time in  $\{0 \times T, 1 \times T\}$ , while  $B$  will choose a waiting time in  $\{0 \times T, \dots, 3 \times T\}$ . What is the probability that  $A$  wins this second back off race?
- b) Suppose  $A$  wins the second back off race in (a).  $A$  transmits  $A_2$ , and when it is finished,  $A$  and  $B$  collide again as  $A$  tries to transmit  $A_3$  and  $B$  tries once more to transmit  $B_1$ . What is the probability that  $A$  wins this third back off race?
- c) Given that  $A$  wins the first three back off races, what is a lower bound for the probability that  $A$  wins all of the remaining back off races?
- d) In the case that (c) holds, what happens to the frame  $B_1$ ?

## 4 CSMA/CD: Random Access

Let  $A$  and  $B$  be two stations attempting to transmit a single packet on an Ethernet.

Recall that in case of the  $k$ th collision,  $A$  and  $B$  choose a  $d \in D = \{0, \dots, 2^k - 1\}$  and wait for  $d \times T$  time. Here,  $d$  is chosen randomly from the set  $D$ , where the probability of selecting any element in  $D$  is distributed uniformly.

- a) Let  $P_k$  be the probability of success after the  $k^{th}$  collision in the  $(k+1)^{th}$  attempt. Write  $P_k$  in terms of  $k$ .
- b) Let  $S_k$  be the probability of success in  $(k+1)$  attempts given there is a collision to start with. Write  $S_k$  in terms of  $k$ .
- c) Let  $S$  be the probability of success after  $k$  collisions, at some point in the future. Calculate  $S$ .

Now, we will consider when the probability of selecting elements from  $D$ , i.e. selecting a time slot, is not distributed uniformly.

Specifically, let

$$D = \{0, 1, 2, \dots, 2^k - 1\} \text{ and } P = \{p, 2p, 3p, \dots, 2^k p\}$$

where  $p$  is the solution to

$$p + 2p + 3p + \dots + 2^k p = 1.$$

Let  $p_i$ , the  $i^{th}$  element of  $P$ , be the probability of choosing  $d_i$ , the  $i^{th}$  element of  $D$ . Let  $P_k$  and  $S_k$  be defined as before.

- d) Given the probability distribution above, calculate the probability of success in the second attempt, i.e.  $P_1$ .
- e) Calculate the probability of success in the third attempt, i.e.  $P_2$ . Calculate  $S_2$ .
- f) Write  $P_k$  and  $S_k$  in terms of  $k$ .

Now, assume there are 3 stations,  $A$ ,  $B$  &  $C$ , and a uniform probability distribution in choosing slots.

- g) Can we use the same method as we used in (a) & (b) to calculate  $P_k$  and  $Q_k$ ? Why/why not?

## 5 The Spanning Tree Algorithm

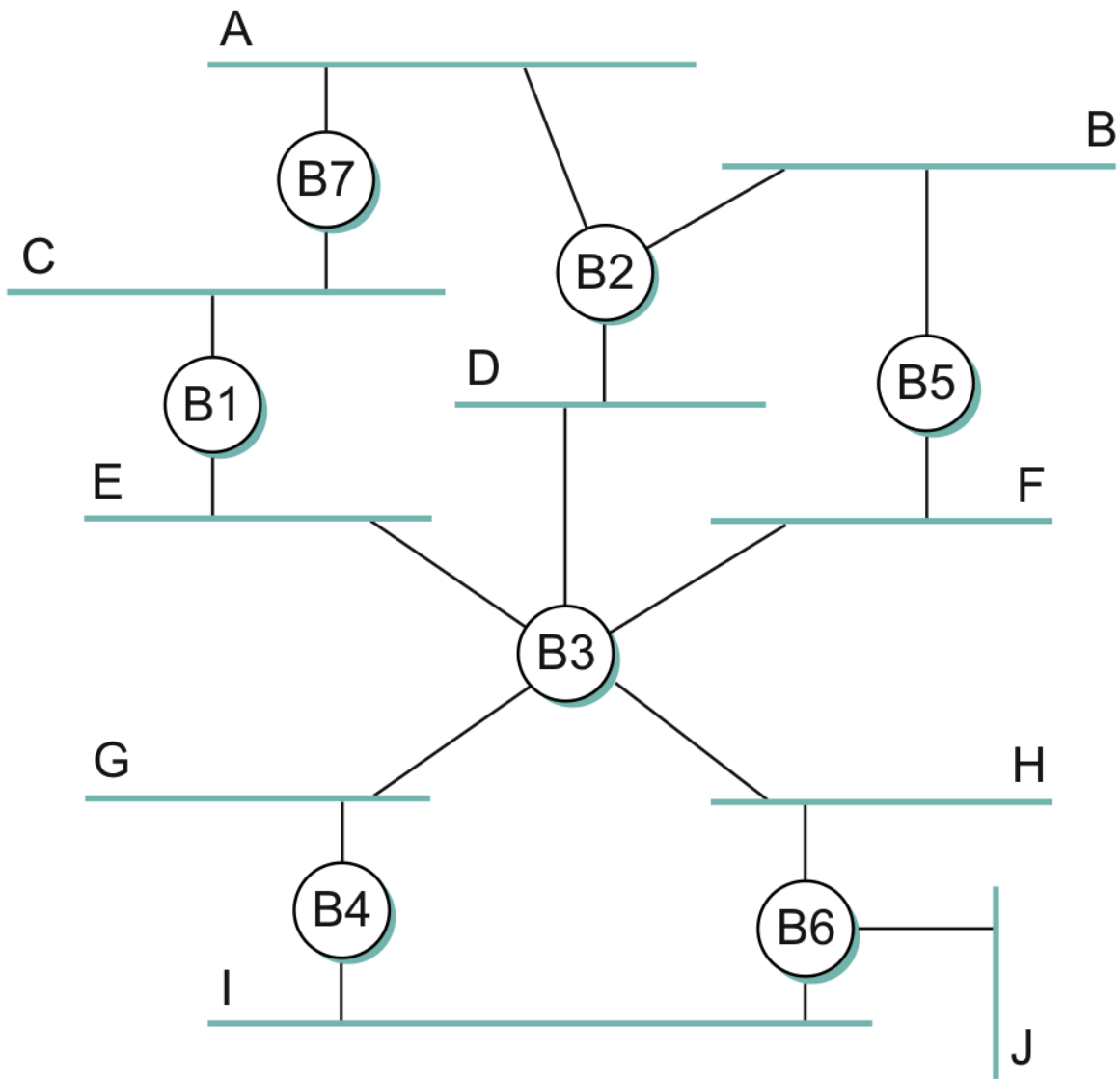

Above an extended LAN and its corresponding network graph is given.

- Which ports are selected by the spanning tree algorithm?
- Assume that the bridge  $B1$  fails. Which ports are selected by the spanning tree algorithm after the recovery process and a new tree has been formed?

## 6 Programming

Suppose  $N$  stations are waiting for another packet to finish on an Ethernet. All transmit at once when the packet is finished and collide.

Write a program to implement the simulation of this case up until the point when one of the  $N$  waiting stations succeeds. Model time as an integer,  $T$ , in units of slot times and treat collisions as taking one slot time (e.g. a collision at time  $T$  followed by a backoff of  $k = 0$  should result in a retransmission attempt at time  $T + 1$ ).

- a) Find the average delay before one station transmits successfully, for  $N=5$ ,  $N=10$ ,  $N = 20$ ,  $N = 40$ , and  $N = 100$ .
- b) Plot the average delay against the number of stations. How is delay related to the number of stations?